



Experiences and Planning of Flight Recording Systems employed at the Langley Research Center: An Overview

Kevin Vipavetz, Frank Vassey, Dan Norfolk and Tom Shull

NASA Langley Research Center

Hampton VA 23681-0001

Phone: +1-757-864-3805/3806; FAX: +1-757-864-8674

K.G.vipavetz@larc.nasa.gov

Presented at the THIC Meeting at the Omni International

Newport News VA 23606

Tuesday, October 14, 1997

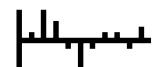

MOUNTAIN OPTEC MAGNETO OPTICAL DRIVE INSTALLATION IN NASA OV-10



MOUNTAIN OPTEC
MAGNETO OPTICAL
DISK DRIVE



OV-10 MOUNTAIN OPTEC RECORDING SYSTEM

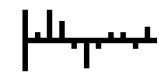
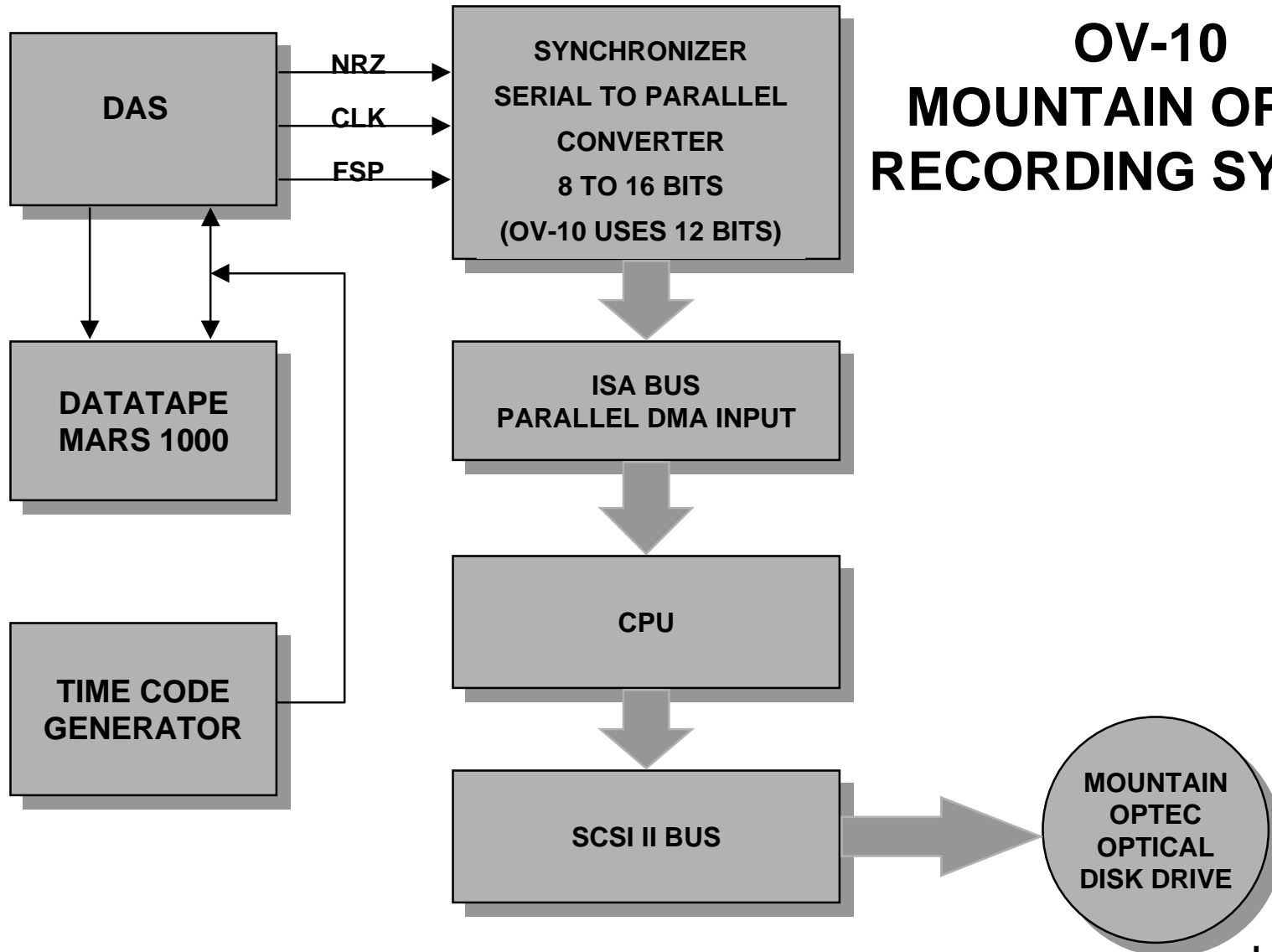

DATATAPE MARS II INSTALLATION IN NASA B-757



TAPE TRANSPORT MODULE

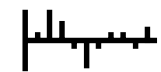

DATATAPE MARS II INSTALLATION IN NASA B757



ELECTRONICS MODULE



B-757 DATA ACQUISITION SYSTEM

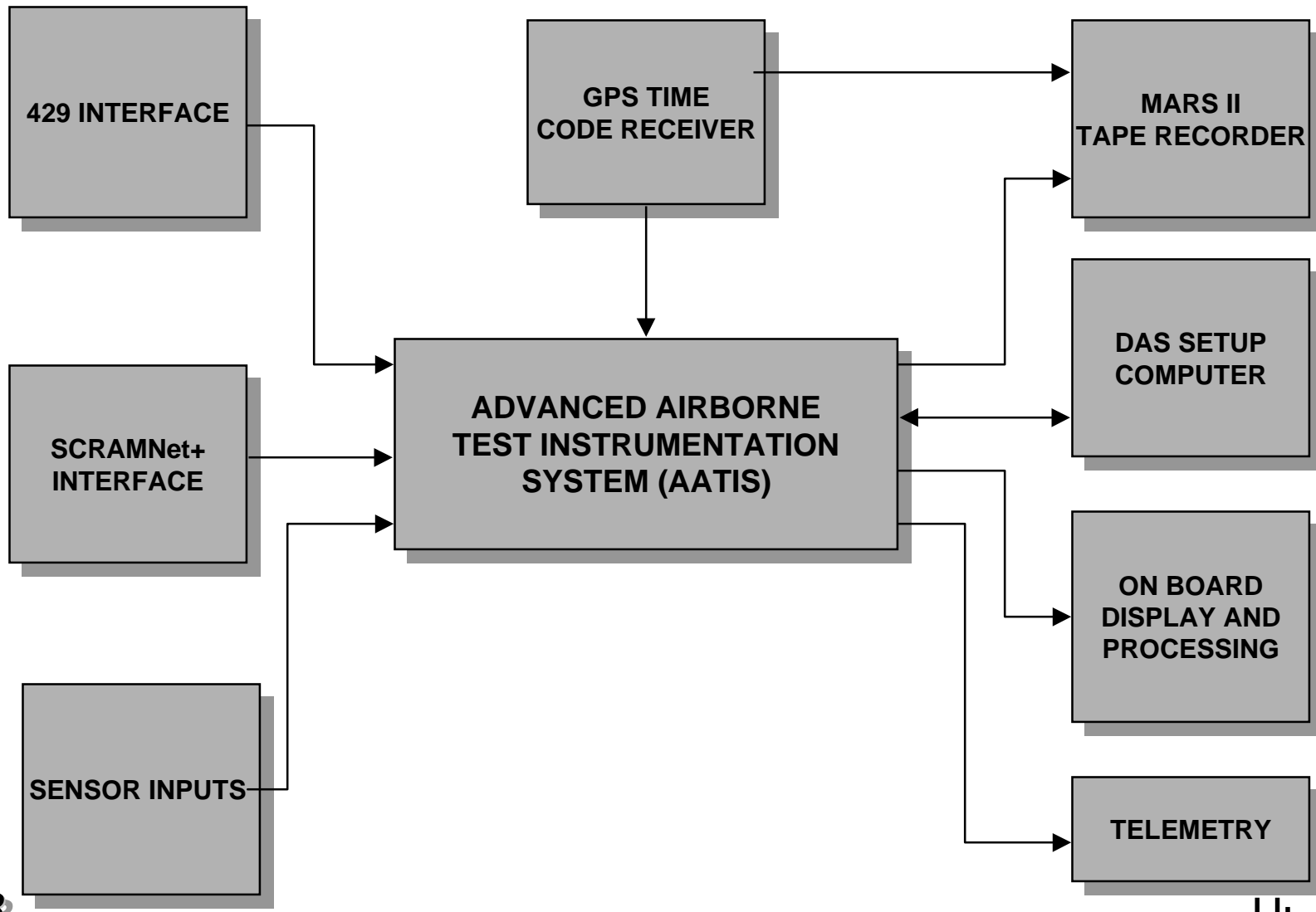

ADAPS GROUND STATION

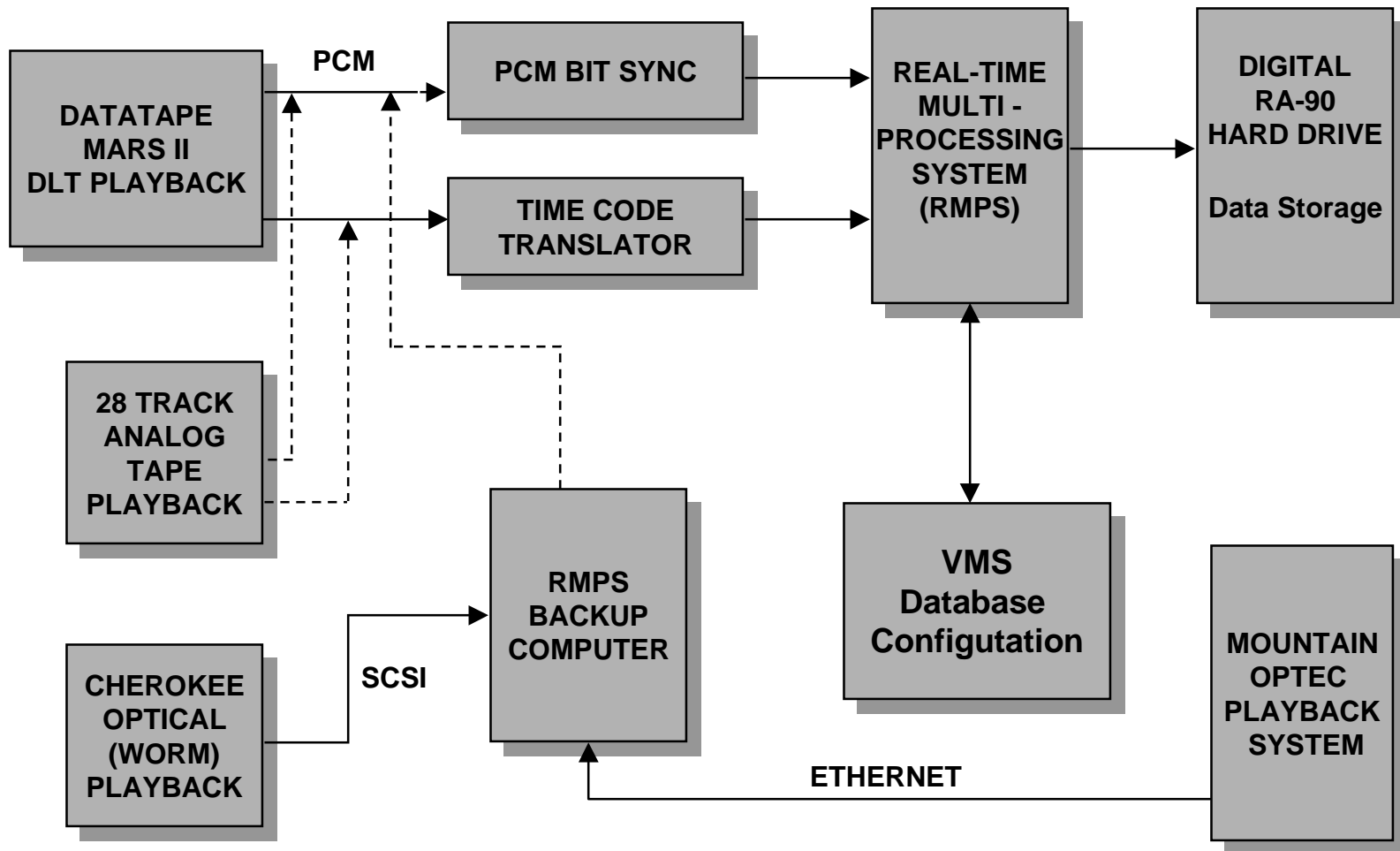

AEROSPACE DATA ACQUISITION and PROCESSING STATION

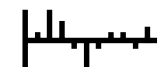

DATATAPE MARS II INSTALLATION IN ADAPS



TAPE TRANSPORT



ELECTRONICS MODULE

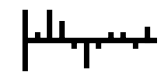



- **Where We're Goin'**

Optical disk development for the B757
Fast playback capability using the Mars II
Digital Variable Disk (DVD) technology
FAA / airline flight recorder technology
Flashcard technology



- **The Perfect Device**

High Bandwidth

High Storage Capacity

Low Cost (Instrument & Media)

Flight and Ground versions

Low Maintenance

No moving parts

Small Size and Weight

High speed search & retrieval (Random access)

User Friendly

Uses IRIG Standards



Summary

- **Flight**
- **Ground**